

General Purpose Transistors

PNP Silicon Features

- We declare that the material of product compliance with RoHS requirements.
- S- Prefix for Automotive and Other Applications Requiring Unique Site and Control Change Requirements; AEC-Q101 Qualified and PPAP Capable.

ORDERING INFORMATION

Device	Package	Shipping
2SA1037AKQ/R/S S-2SA1037AKQ/R/S	SOT23	3000/Tape & Reel

MAXIMUM RATINGS

Rating	Symbol	Value	Unit
Collector–Emitter Voltage	V_{CEO}	-50	V
Collector–Base Voltage	V_{CBO}	-60	V
Emitter–Base Voltage	V_{EBO}	-6.0	V
Collector Current — Continuous	I_C	-150	mAdc
Collector power dissipation	P_C	0.2	W
Junction temperature	T_j	150	°C
Storage temperature	T_{stg}	-55 ~ +150	°C

DEVICE MARKING

2SA1037AKQ =FQ	2SA1037AKS=G3F	2SA1037AKR=FR
----------------	----------------	---------------

ELECTRICAL CHARACTERISTICS ($T_A = 25^\circ\text{C}$ unless otherwise noted.)

Characteristic	Symbol	Min	Typ	Max	Unit
Collector–Emitter Breakdown Voltage ($I_C = -1\text{ mA}$)	$V_{(BR)CEO}$	-50	—	—	V
Emitter–Base Breakdown Voltage ($I_E = -50\ \mu\text{A}$)	$V_{(BR)EBO}$	-6	—	—	V
Collector–Base Breakdown Voltage ($I_C = -50\ \mu\text{A}$)	$V_{(BR)CBO}$	-60	—	—	V
Collector Cutoff Current ($V_{CB} = -60\text{ V}$)	I_{CBO}	—	—	-0.1	μA
Emitter cutoff current ($V_{EB} = -6\text{ V}$)	I_{EBO}	—	—	-0.1	μA
Collector-emitter saturation voltage ($I_C / I_B = -50\text{ mA} / -5\text{ mA}$)	$V_{CE(sat)}$	—	—	-0.5	V
DC current transfer ratio ($V_{CE} = -6\text{ V}$, $I_C = -1\text{ mA}$)	h_{FE}	120	—	560	—
Transition frequency ($V_{CE} = -12\text{ V}$, $I_E = 2\text{ mA}$, $f = 30\text{ MHz}$)	f_T	—	140	—	MHz
Output capacitance ($V_{CB} = -12\text{ V}$, $I_E = 0\text{ A}$, $f = 1\text{ MHz}$)	C_{ob}	—	4.0	5.0	pF

h_{FE} values are classified as follows:

*	Q	R	S
h_{FE}	120~270	180~390	270~560

2SA1037AK Series S-2SA1037AK Series

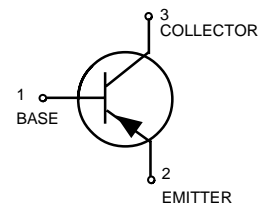
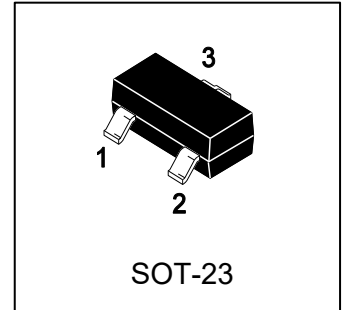

Fig.1 Grounded emitter propagation characteristics

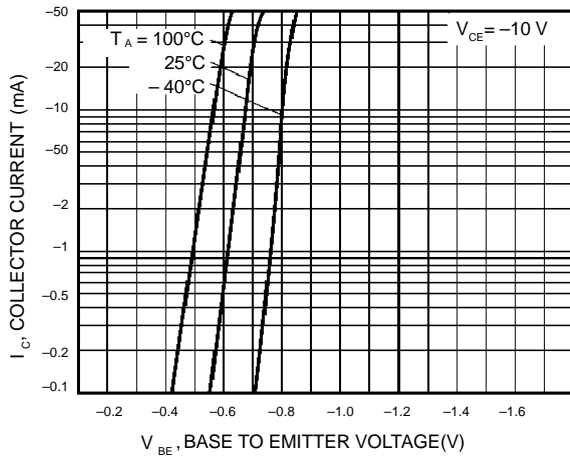

Fig.2 Grounded emitter output characteristics(I)

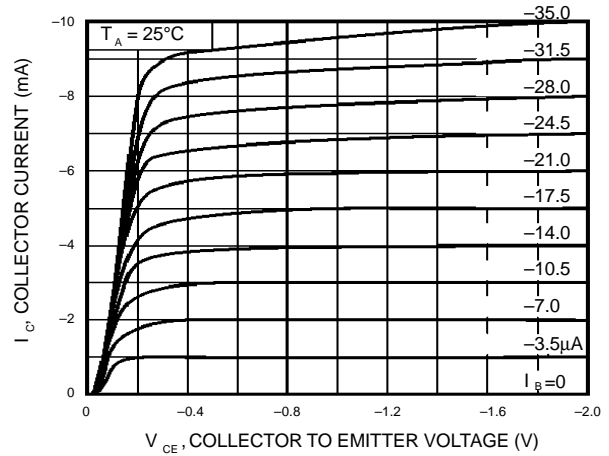

Fig.3 Grounded emitter output characteristics(II)

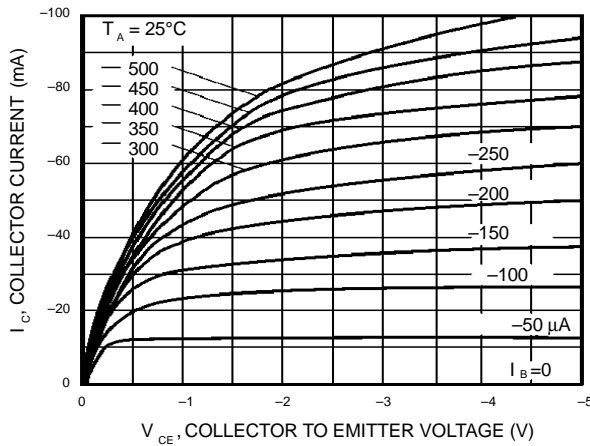

Fig.4 DC current gain vs. collector current (I)

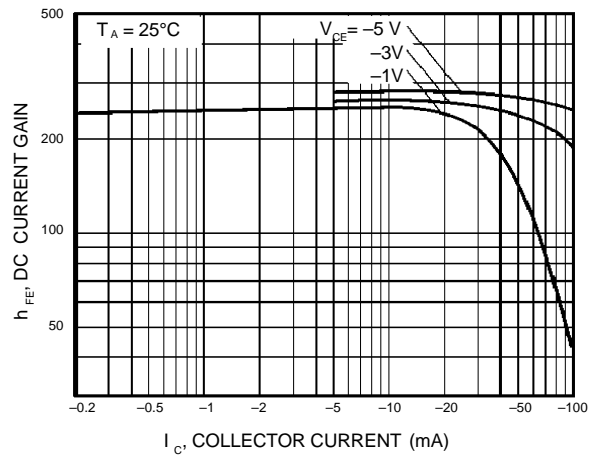

Fig.5 DC current gain vs. collector current (II)

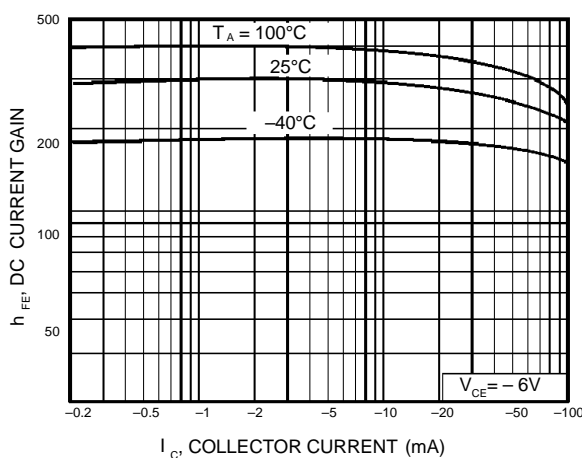

Fig.6 Collector-emitter saturation voltage vs. collector current (I)

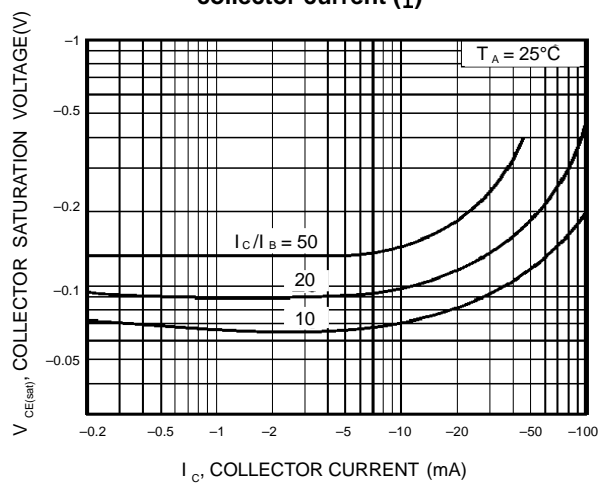

Fig.7 Collector-emitter saturation voltage vs. collector current (I)

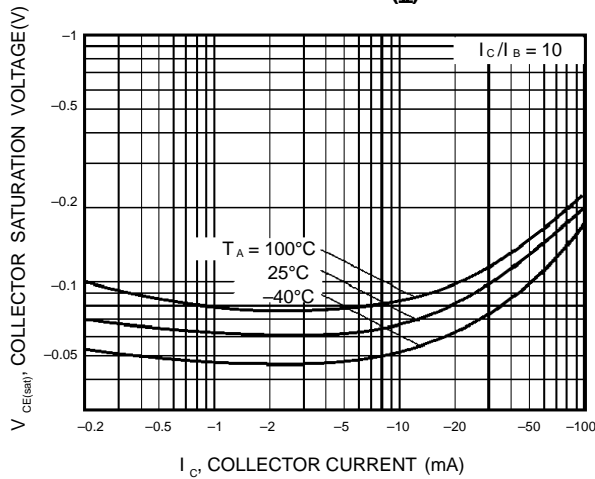
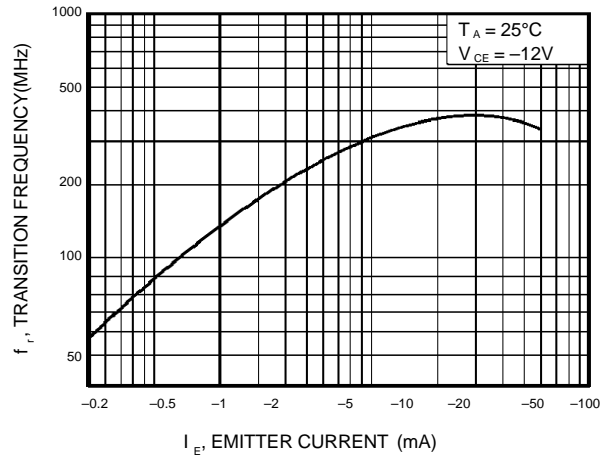
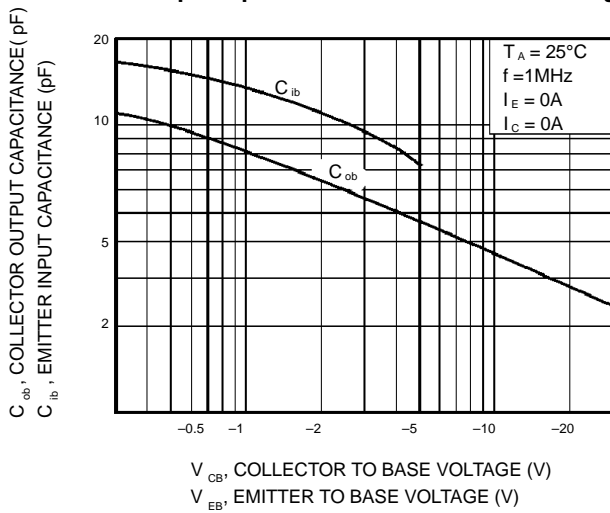

Fig.8 Gain bandwidth product vs. emitter current



**Fig.9 Collector output capacitance vs. collector-base voltage
Emitter input capacitance vs. emitter-base voltage**



SOT-23

NOTES:

1. DIMENSIONING AND TOLERANCING PER ANSI Y14.5M,1982
2. CONTROLLING DIMENSION: INCH.

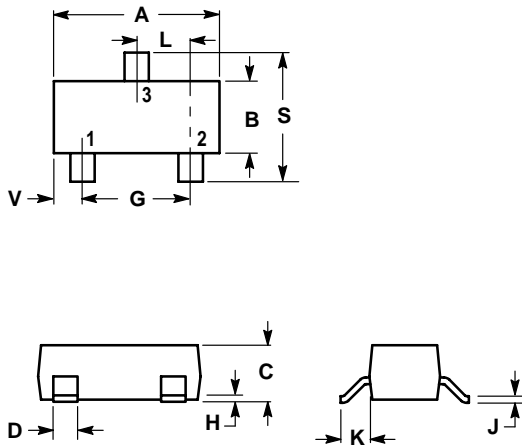

DIM	INCHES		MILLIMETERS	
	MIN	MAX	MIN	MAX
A	0.1102	0.1197	2.80	3.04
B	0.0472	0.0551	1.20	1.40
C	0.0350	0.0440	0.89	1.11
D	0.0150	0.0200	0.37	0.50
G	0.0701	0.0807	1.78	2.04
H	0.0005	0.0040	0.013	0.100
J	0.0034	0.0070	0.085	0.177
K	0.0140	0.0285	0.35	0.69
L	0.0350	0.0401	0.89	1.02
S	0.0830	0.1039	2.10	2.64
V	0.0177	0.0236	0.45	0.60

